

Installation Instructions

Surface Fixed

Harmony Bell
Page 1 of 3



Components:

-  x1
M10x40 Security Screw
-  x1
M10 Barrel Nut
-  x4
2 Part Cover Cap

Metric Conversion:
1650mm/ 64 61/64"
1500mm/ 59 1/16"
1350mm/ 53 5/32"
1.5m/ 59"

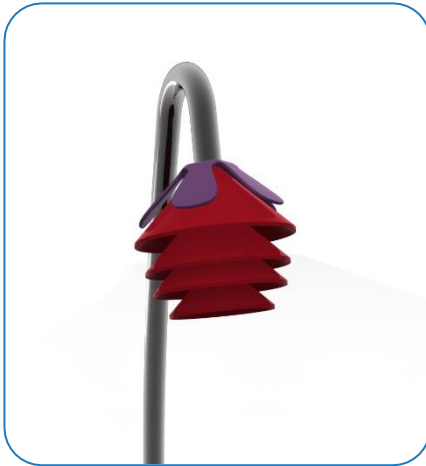

Weight of heaviest part **8kg** (Large Bell)

1. Unpack ground fixing leg 1no.
2. Lay packaging out on floor or assemble on non-abrasive surface to prevent marking of polished stainless steel.
3. Align holes on leg to holes on surface fixing plate (opposite end to polished domes) and secure in place using 1no. M10 x 40mm Screw and Barrel Nut provided. Tools required TX 45 Driver Bits)

4. Invert assembled frame so Bells are at the top.

5. **Locate Bells** in desired location and mark holes to fix to surface.

6. Fix to Surface using recommended ground anchors (**Ground Anchors are not supplied**)

7. Make sure all fixings are covered and secure using cover caps provided



Small Beaters X1

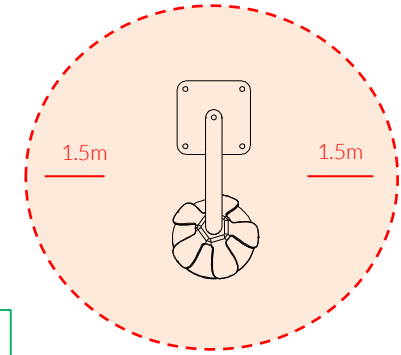

Install Instrument with 1.5m free space (from widest point) around it.

Large 1650mm
Medium 1500mm
Small 1350mm
from plate

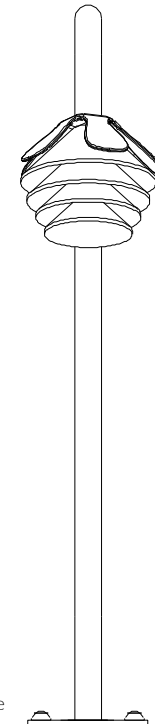

Ground Anchors not supplied



Spares available from percussionplay.com or from your local distributor

14 Kg

Installation Instructions

Remove nylon nut and 40mm spacer to expose threadlocker, and screw bell into post.

Surface Fixed

Harmony Bell
Page 2 of 3



Components:



Metric Conversion:
400mm/ 16"
1650mm/ 64 61/64"
1500mm/ 59 1/16"
1350mm/ 53 5/32"
1.5m/ 59"

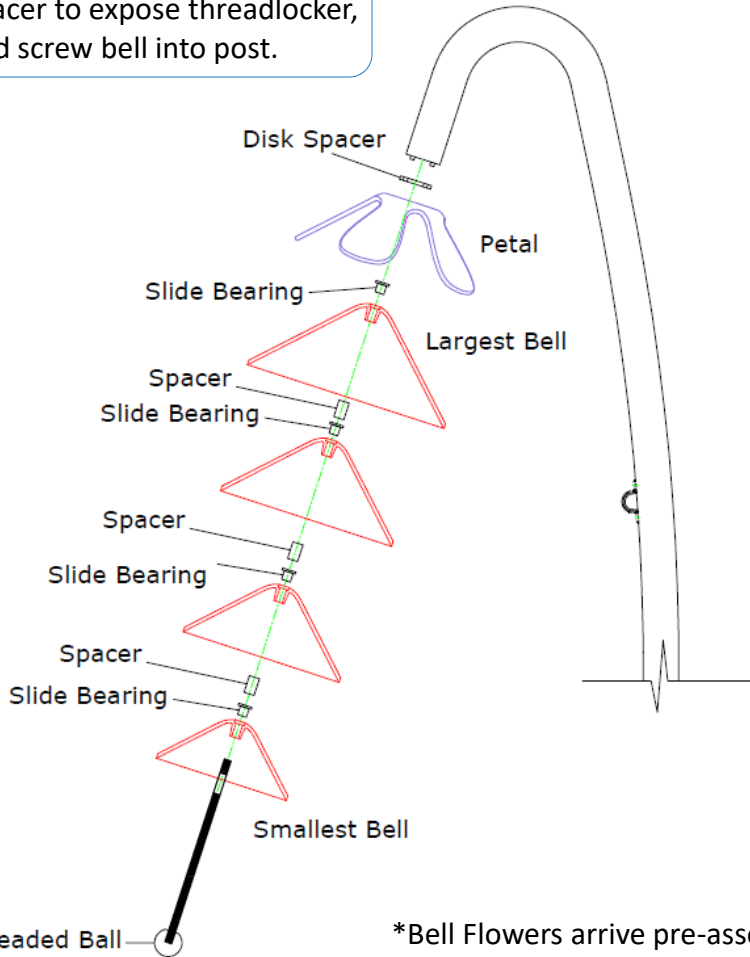

*Bell Flowers arrive pre-assembled.

PETAL & BELL COLOUR COMBINATIONS

Major Posy

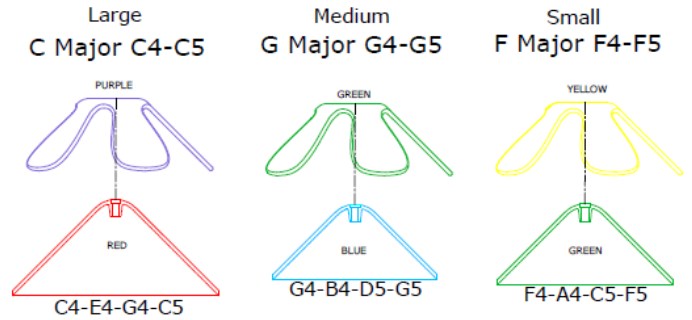

Minor Posy

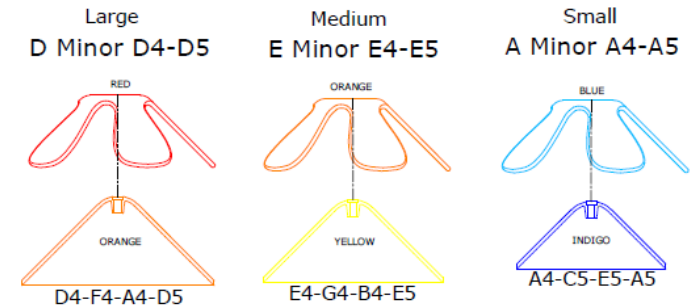

Small Beaters X1



Spares available from
percussionplay.com or from your
local distributor

14 Kg

Tools:

 x1
TX 45 Driver Bit

Surface Fixed

Harmony Bell
Page 3 of 3



Components:

 x1
M10x40 Security Screw

 x1
M10 Barrel Nut

 x4
2 Part Cover Cap

Thread Lock Solution
Required (Not Supplied)

1

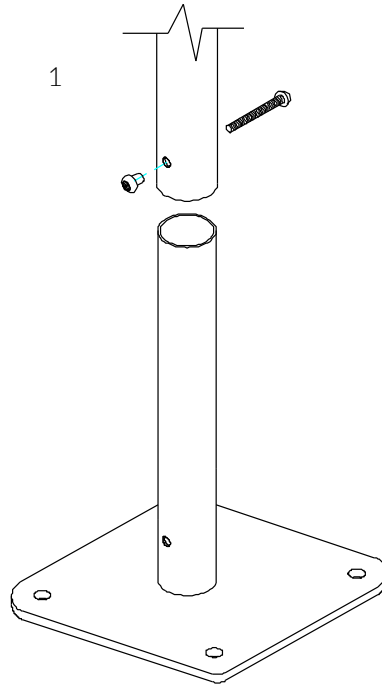

Locate the Surface fix Plate into the leg of the instrument.

2

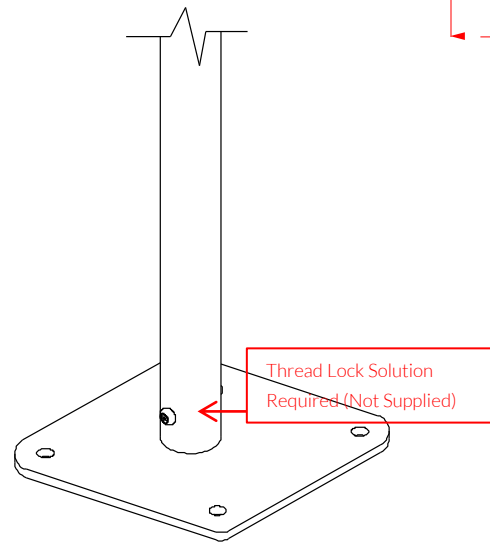

Fix instrument to Surface fix plate using M10 bolt and Barrel Nut and use **thread locking solution** to prevent fixings working loose.

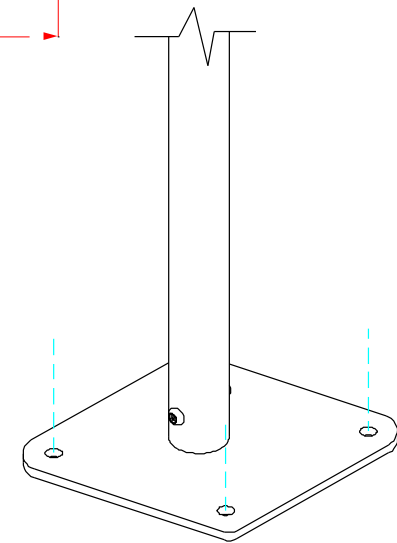
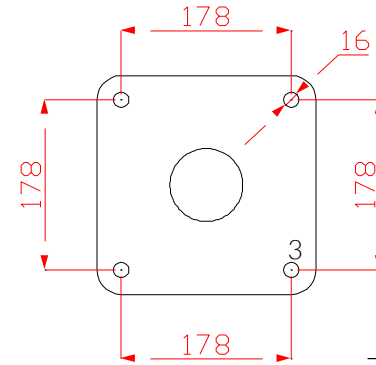

Fix Surface Plate to the ground surface **Ground Anchors Not provided** cover fixings with caps provided



Small
Beaters X1

Ground Anchors
not supplied



Spares available from
percussionplay.com or from your
local distributor

30 Kg